

DOI 10.33099/2618-1614-2026-32-1-41-54
UDC 531.55

K. F. Boriak,

*Doctor of Technical Science, Professor, Naval Institute,
National University «Odessa Maritime Academy»,*

O. I. Kravchuk,

*Candidate of Technical Science, Senior Researcher,
Military Academy (Odessa),*

O. M. Lymarenko,

*Candidate of Technical Science, Associate Professor,
Odessa Polytechnic National University,*

Ye. V. Buchka,

Odessa Polytechnic National University,

M. K. Boriak,

*State University of Intelligent Technologies
and Telecommunications*

A Study of the Influence of Correction of Dynamic Unbalance of 152 mm Artillery Projectile on the Strength of Its Body

Improving the accuracy of hitting a given target is a pressing issue for artillery theorists, servicemen of artillery units, as well as artillery projectile manufacturers. The article analyses various methods of correcting the unbalance vector of large-calibre artillery projectiles, which are proposed by various manufacturers and inventors during projectile production to improve quality and enhance the competitiveness of their products in the global arms market. By means of the conducted testing and done calculations at computer-simulated models, the influence of the operation of correcting the dynamic unbalance of mass on the strength of the walls of the artillery projectile body after its metalworking was researched. Ultimately, the permissible geometric dimensions of the groove for the corrective weight, at which the conditions of the calculated margin of the ultimate strength are met, have been found.

Key words: artillery projectiles, residual unbalance, ultimate strength, yield strength, unbalance vector.

© K. F. Boriak, O. I. Kravchuk, O. M. Lymarenko, Ye. V. Buchka,
M. K. Boriak, 2026

The combat operations in Ukraine have been going on for more than three years and are associated with a standoff to exhaust the material and human resources of both warring parties. Despite a great support that Ukraine has from other countries, the long-term standoff is quite risky for Ukraine, since the Russian military industrial complex potential is greater than the Ukrainian one. Since the construction of new factories is associated with large financial costs and is complicated by constant Russian missile and drone attacks, a technical breakthrough in the production of modern weapons and military equipment using the existing experience of combat operations, which is quite reasonable to use to improve existing techniques and production capacities for manufacturing the weapons and equipment within local industrial sites, could improve the current situation for Ukraine.

The combat operations in Ukraine have been going on for more than three years and are associated with a standoff to exhaust the material and human resources of both warring parties. Despite a great support that Ukraine has from other countries, the long-term standoff is quite risky for Ukraine, since the Russian military industrial complex potential is greater than the Ukrainian one. Since the construction of new factories is associated with large financial costs and is complicated by constant Russian missile and drone attacks, a technical breakthrough in the production of modern weapons and military equipment using the existing experience of combat operations, which is quite reasonable to use to improve existing techniques and production capacities for manufacturing the weapons and equipment within local industrial sites, could improve the current situation for Ukraine.

One of the ways to reduce the shortage of artillery projectiles can be considered a number of problems to improve the accuracy of hitting targets during firing [1]. Solving such problems is associated with the technical state of artillery guns, the design of the projectile, the meteorological preparation of data for firing, the level of training of the gun crew and its experience in conducting combat operations, as well as the stability and predictability of the ballistic trajectory of the projectiles in the air until the target is hit.

Problem statement in general

Any gun (including howitzer) is a complex combat system that has its own design and operational characteristics, that is, the main indicators of the perfection of the design and combat power of the gun are precisely its characteristics. Based on the purpose of artillery and the tasks performed, the range, accuracy,

and precision of fire that depends on many factors can be singled out as the main characteristics. The range of fire depends on the design of the projectile, the initial speed of its movement and the angle of elevation of the barrel. The accuracy of fire is related to the measure of deviation of the mean point of impact (MPI) from the desired MPI, and the precision of fire is related to the measure of consistency of the MPI [2]. The accuracy and precision of fire depend on the state of a particular weapon (the quality of the metal from which the gun barrel was made, the service life of the barrel based on the quantity of shots taken, the serviceableness of the counterrecoil mechanism, the balancing mechanism, etc.), the values of possible deviations in the main parameters of firing (sighting devices, projectiles, etc.), and also the firing conditions (pressure, humidity, air temperature, wind speed and direction, etc.).

Thus, all the parts and mechanisms of an artillery gun (including howitzer) work as a single complex mechanism (system) and in almost all indicators one of the main roles is played by the means of destruction of the enemy – the projectile: its design, the quality of the material, and the perfection of manufacture. Improving the quality of large-calibre artillery projectiles produced for guns with

rifled barrels is a pressing issue, because the more stable and predictable the ballistic trajectory of the projectiles [3], the less their quantity is consumed to hit each single target on the battlefield and, accordingly, the better the result of artillery fire – more military losses for the enemy and less material costs and losses in the Ukrainian Armed Forces.

Analysing the recent published achievements

It is known from the artillery firing textbooks [4] that the divergence of the centre of gravity from the centre of aerodynamic resistance is the main reason for the occurrence of nutation of a projectile in flight through the pairs of forces acting on the projectile: the centrifugal force arising from the rotation of the unbalanced mass of the projectile, perpendicular to the horizontal dynamic axis, and the force of aerodynamic resistance directed along the horizontal geometric axis of the projectile and applied at the centre of aerodynamic resistance. *Figure 1* shows two relevant cases of the paired arrangement of the centrifugal force and aerodynamic drag force of a flying projectile, discussed in detail in paper [5].

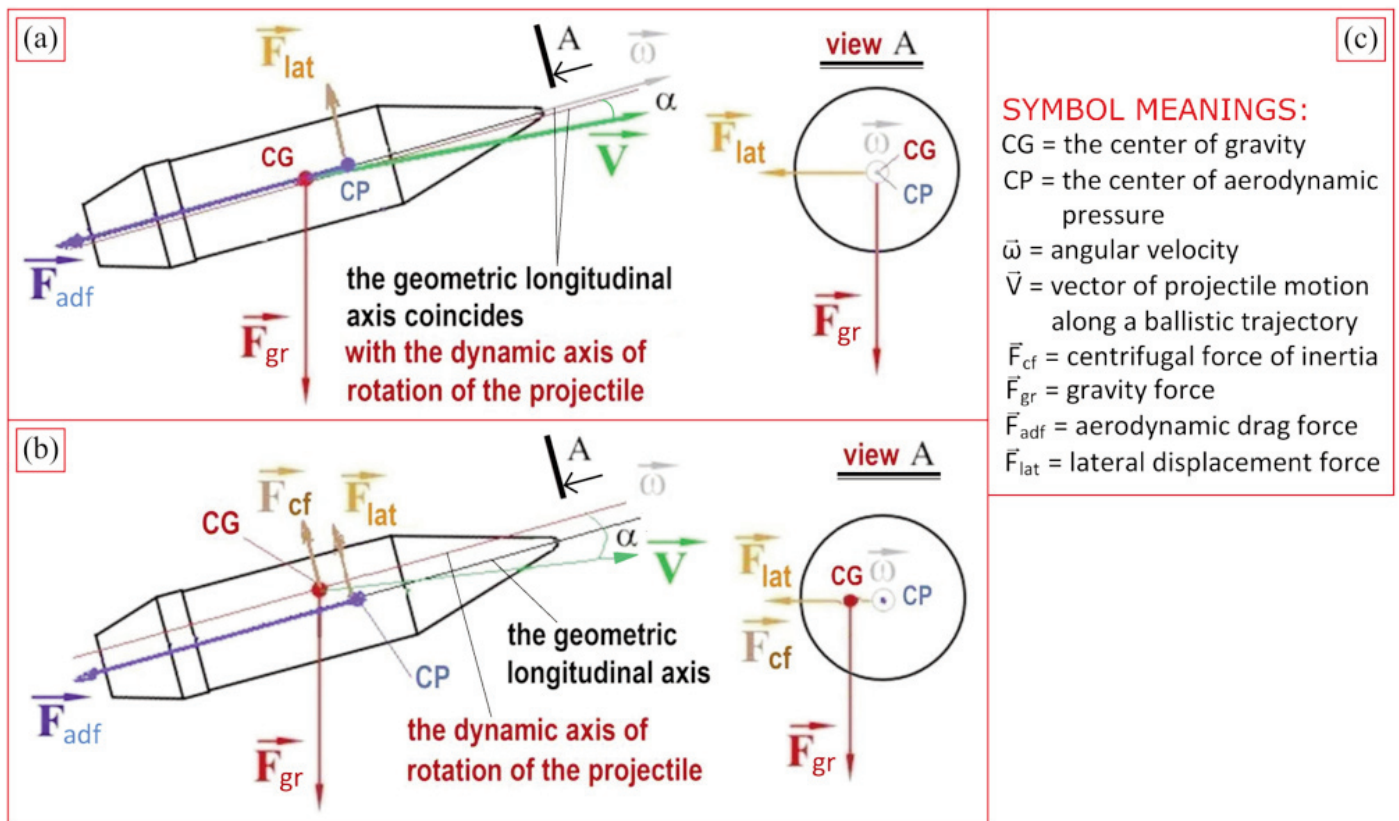

Figure 1. Location of forces when CG and CP do not coincide and:
 (a) they lie in the coincident axes; (b) they lie in the non-coincident axes; (c) explanations to images

Paper [5] examines a solution to the problem of reducing the range of variation (scatter) in the values of projectile drift in the air by improving the existing method of manufacturing artillery projectiles at the expense of an additional operation of correcting (reducing) the unbalance vector. Such an operation will allow reducing both the drift of the projectile in flight and its lateral deviation, as well as stabilizing the kinematics of its movement along a ballistic trajectory, which will ultimately lead to an increase in its flight range and increase the accuracy of hitting a given target.

In paper [6], manufacturing versions for the practical implementation of the operation of correcting the unbalance vector of projectiles in one plane are proposed by adding a certain mass of metal in the form of a corrective weight, the mass of which and the corresponding setting angle in the plane of correction are determined during the process of balancing the projectile

on a balancing stand, taking into account the placement of such a weight in a special groove (in accordance with patent [7]), made along the circumference in the end rear part of the projectile body and which can be pre-cut on a metalworking machine during the general processing of the projectile body. Besides, paper [6] proposes manufacturing versions for removing particles of excess metal from the end part of the projectile body by milling (or drilling) recesses in the corresponding corner in the plane of correction, where the number and geometric dimensions of the recesses are pre-determined during the balancing process on a balancing stand (see Fig. 2).

Based on the above-mentioned versions of the method for correcting the unbalance vector of artillery projectiles, patent [8] has proposed to carry out calibrating and correspondingly marking the projectiles by 5 groups on the basis of two parameters: according to

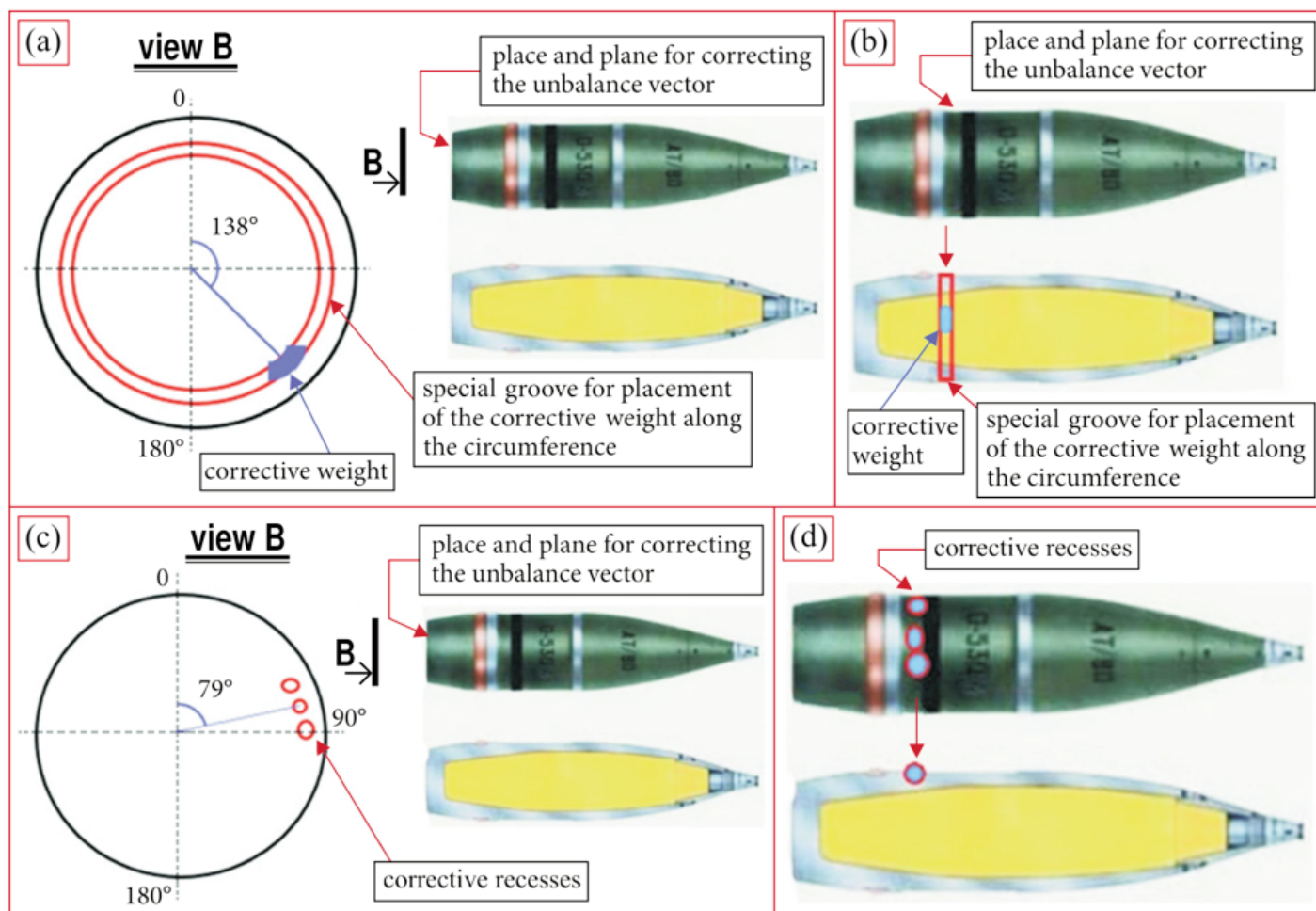

Figure 2. Versions of correcting the unbalance of the projectile:
 (a) and (b) by adding metal mass through a corrective weight placed in the groove in the end rear part and on the lateral surface, respectively; (c) and (d) by removing the mass of excess metal through milling in the end rear part and on the lateral surface, respectively

the value of static mass and according to the amount of residual unbalance (dynamic unbalance).

In patent [9], in order to improve the quality control of artillery projectiles at the expense of reducing the range of variation (scatter) of drift values, an additional manufacturing operation (within the production process) for sorting the projectiles both by the static mass parameter and by dynamic unbalance through the amount of residual unbalance has been proposed.

In 2023, engineers of Rheinmetall Waffe Munition GmbH (Germany), a well-known powerful manufacturer of military equipment, weapons, and artillery projectiles in Europe, patented a method for correcting (reducing) the unbalance vector of projectiles during their production [10]. The main idea of this method is based on the preliminary displacement and/or tilt of the existing geometric axis of the projectile body to the corresponding position of the inertial axis of rotation, which is preliminarily calculated mathematically based on the amount of unbalance obtained on the balancing stand at the expense of the uneven reduction in wall thickness along the projectile body by mechanical processing (milling or grinding) on metalworking machines (see Fig. 3).

The method proposed by German engineers [10] specifies the following sequence of manufacturing operations during the production of projectiles:

- Measuring the unbalance vector.
- Calculating the displacement of the central points on the rear and throat openings of the body.

- Creating new hold-down surfaces on the end of the body (if necessary).
- Mechanically processing the outer contour of the body.

A patent issued more than thirty years ago to Swedish engineers [11] indicates that the operation of correcting (eliminating) the unbalance of an artillery projectile is carried out by determining the points of the unbalance vector and changing the mass of the projectile at these points using adjusting washers selected from a set of calibrated washers of different weights and eccentricities and their welding onto the end rear parts of the projectile bodies. According to the description in this patent [11], the operation of correcting the unbalance of projectile is performed after measuring the amount of unbalance on a balancing stand by means of selecting and welding an adjusting washer calibrated by weight and eccentricity (see Fig. 4).

However, the text of the description does not contain any information on how the additional and uncertain mass of filler material used to weld this washer to the projectile body is taken into account. It is quite obvious that the welded adjusting washers (calibrated by weight) together with the added filler material (during welding) of unknown weight themselves become the source of a new amount of unbalance of the projectile, which also needs to be corrected, therefore preliminarily calibrating the adjusting washers by weight and eccentricity is meaningless. Despite the fact that the inventors according to the patent [11] claim that the adjusting

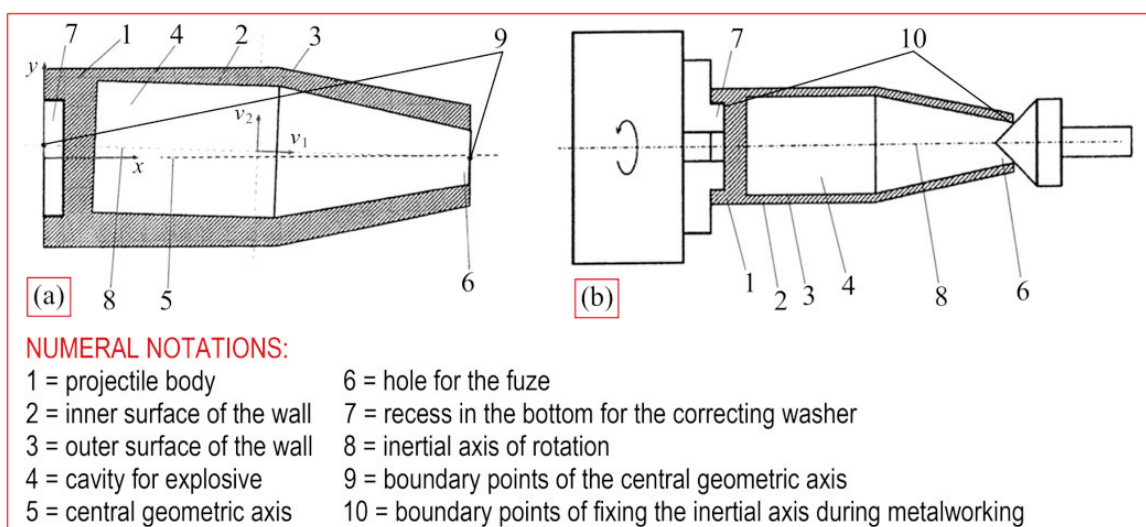

Figure 3. A cross-sectional drawing associated with the method for correcting the unbalance vector of the body: (a) measuring the unbalance vector and calculating the offset of the central points on the rear and throat openings of the body; (b) mechanical processing of the outer contour of the body on a metalworking machine

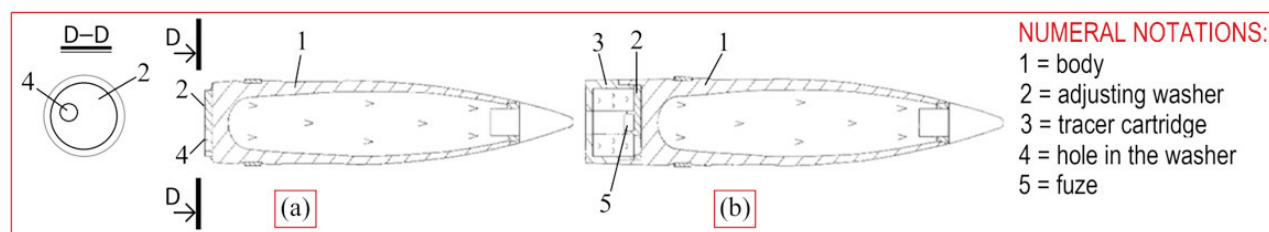

Figure 4. Options for the placement of corrective weight in the form of an adjusting washer with a hole:
(a) the washer is placed on the end of the outside of the body; (b) the washer is placed inside
in a tracer cartridge in the rear part of the body

washer welded to the end of the projectile body does not change the characteristics of the ballistic flight and does not violate the aerodynamic properties of the projectile, in fact, by reason of the increase in the length of the projectile (by the thickness of the washer), the centre of gravity of the projectile shifts closer to its end (bottom). And this, in turn, leads to an increase in the distance between the centre of gravity and the centre of aerodynamic pressure (see Fig. 1). Thus, the method of correcting the amount of the residual unbalance of projectiles due to the specified shortcomings (within the techniques) declared in the patent [11] cannot ensure high quality of their calibration by the dynamic unbalance parameter of projectile mass.

According to the descriptions in the said patents [10] and [11], the amount of unbalance of projectile is first determined on a special balancing stand, and then the projectile is carried to a metalworking machine, where the operation of correcting the unbalance vector of the hollow projectile body is performed without additional explosive mass. Ultimately, the proper degree of elimination of the dynamic unbalance of the projectile cannot be ensured, since the operation of correcting does not take into account the additional uncertain mass of explosive, which can be unevenly distributed in density inside the projectile body and thereby increase the amount of the residual unbalance.

In mechanical engineering, a distinction is made between preliminary and final balancing of parts and assemblies [12]. The preliminary balancing is performed for each component of a cylinder-shaped assembly (for example, a rotor) separately on intermediate stages of manufacturing, and the final balancing is performed after assembling the parts into a single unit. The present-day techniques of manufacturing the projectiles imply assembling the projectile body from individual components after appropriate metalworking. The first (preliminary) balancing operation is recommended to be performed before assembling the projectile body for each part separately. The second (intermediate) balancing operation is recommended to be performed after

assembling the projectile body into a single unit. The third (final) balancing should be performed when the inner part of the projectile body is already filled with explosive and the projectile has maximum mass. Only in such a sequence of three balancing operations, the high-quality calibration of the produced projectiles can be achieved and their appropriate marking by 5 groups can be performed.

It should be noted separately that the widely known document concerning ammunition [13], which was published 40 years ago, does not contain any data confirming that the operation of calibrating projectiles according to the static mass parameter should be performed “before” or “after” the operation of eliminating the dynamic unbalance vector of the projectile, and there is also no description of the operation of marking projectiles in a given sequence of manufacturing operations during their outputting. Besides, in the case of applying the method of correcting the unbalance vector by means of welding, as described in the patent issued to Swedish engineers [11], it is technologically impossible to perform the final balancing of a projectile filled with explosive without violating fire safety requirements.

According to the patent [10], the claimed method of correcting the unbalance vector is proposed to be used at the preliminary stage of manufacturing a hollow projectile using an additional special operational mandrel installed on the spindle of a metalworking machine to ensure displacement and/or tilt during rotation of the existing geometric axis of the projectile body in the end part when correcting the unbalance vector. However, the patent issued to German engineers [10] does not contain a description of the process of using the claimed method for the final balancing of the projectile when it is already filled with explosive, so the question of performing the final balancing of the projectile remains unanswered.

In our opinion, of all the methods considered above, the most technologically advanced and understandable is the method proposed in the Ukrainian patent [8], according to which the final balancing operation of

artillery projectiles is carried out when they are already filled with explosive and have maximum mass, where the added corrective weights or removed excess metal particles (by milling the recesses at the points of unbalance vector) by their values of mass and eccentricity precisely correspond to the amounts of residual unbalance measured on the balancing stand (see Fig. 2), and at the expense of the accuracy of correcting the amount of residual unbalance, the high quality calibration of the produced projectiles can be achieved. If necessary, the manufacturing operation of correcting the dynamic unbalance of the projectile and conducting the control measurement of the amount of residual unbalance after placing the corrective weights or milling (drilling) can be performed many times until the desired result is obtained, without removing the projectile from the supporting spindles of the balancing stand, unlike the methods described in the patents [10] and [11].

The goal of this article is to propose (to manufacturers) a solution to the problem of increasing the accuracy of hitting a given target with 152 mm artillery projectiles when fired from guns with a rifled barrel at the expense of stabilizing the flight of projectiles along a ballistic trajectory by way of improving the techniques of projectile production.

Conducted testing and obtained data

It is quite obvious that the selection of the method of correcting the unbalance vector and the operation itself must be carried out taking into account the requirements of maintaining the overall strength of the end part of the projectile body, which must withstand the maximum permissible gas pressure before the rotating band of 300 MPa ($= 3,000 \text{ bar} = 300,000 \text{ kN/mI}$) when firing from a gun with a rifled barrel. According to the textbook by

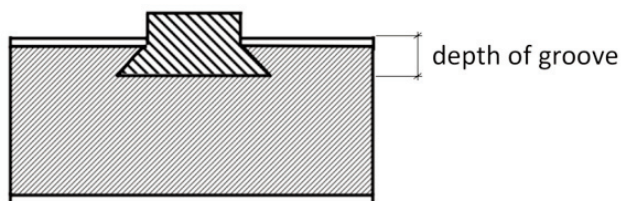

Figure 5. Placement of the rotating band in the wall of the projectile body

Derevyanchuk [14], the rotating band is fixed in annular groove made in the form of a dovetail in the wall of the projectile body, the depth of which is 0.02–0.03 cal. (see Fig. 5).

The groove for the rotating band is milled in the lower part of the projectile (the actual wall thickness in this place for a 152 mm calibre projectile is 28 mm), and the depth of this groove, in accordance with the data of the textbook [14], varies within the range of 3.0–4.5 mm ($152 \cdot 0.02 = 3$ and $152 \cdot 0.03 = 4.5$). Consequently, the wall thickness of the projectile body decreases at the location of the rotating band and amounts to 25.0–23.5 mm.

In order to ensure the strength of the fixing of the corrective weight in the groove from the impact of the pressure of the powder gases on it when firing from the gun, it is proposed to make the geometric profile of the groove in the cross section trapezoidal in the form of a dovetail, by analogy with the rotating band, as it is shown in Fig. 5.

The gradual decrease in the wall thickness of the projectile body along the longitudinal axis is shown in Fig. 6. Since the cut groove for the corrective weight reduces the thickness of the sheath of the projectile body

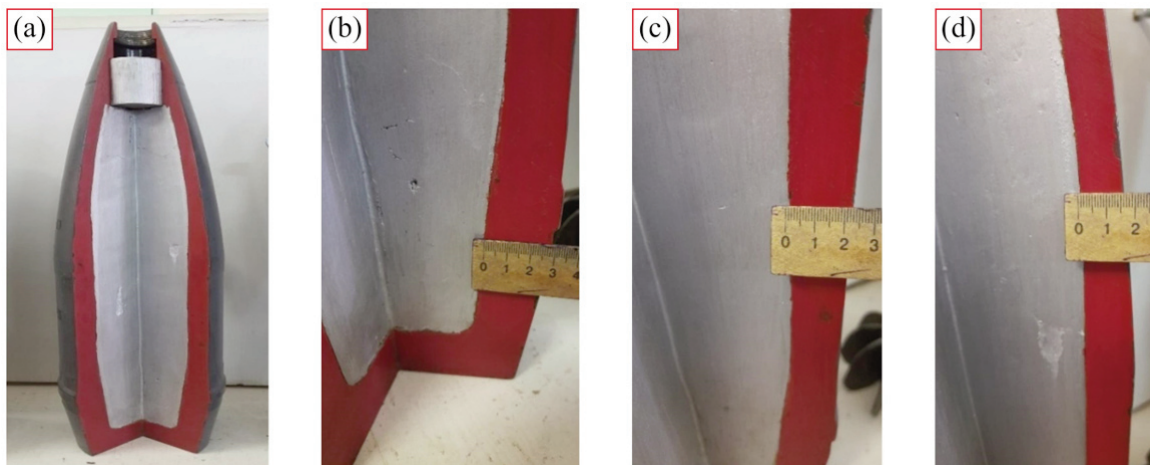

Figure 6. Changes in the wall thickness values of a 152 mm artillery projectile along its length: (a) longitudinal section of the projectile; (b) near the bottom; (c) before the rotating band; (d) after the rotating band

at its location, it became necessary to perform the corresponding calculations to check the strength of the walls of the projectile body taking this groove into account.

The finite element method implemented in the Ansys multi-purpose calculation software complex was used for the calculations. Computer-simulated calculation models were formed according to the initial data and the geometric parameters of the 152 mm artillery projectile (see *Table 1*), given in said textbook [14], taking into account the maximum possible force load from the pressure of the powder gases on the walls of the projectile body during firing.

Table 1

Initial data for calculations

Description of Parameter	Value(s)	Unit
Projectile type: high explosive		
Full length of the projectile, L	4.5–5.5	cal.
Thickness of the sheath of the projectile body, δ	1/8–1/6	cal.
Coefficient of filling the projectile with explosive, α	10–15	%
Relative mass of the projectile, C_q	12–14	kg/dm ³
Relative mass of the bursting charge, C_ω	1.5–2.5	kg/dm ³
Projectile calibre	152	mm
Pressure of powder gases in the bore during firing, P	300	MPa

Since the chemical composition of the walls material of projectile body is kept secret by weapons manufacturers, which is unknown to us, widespread AISI 1045 normalized carbon steel was chosen for the calculations, which is used to manufacture various parts, mechanisms, and structures in mechanical engineering and construction, and has its own set of characteristics. The main characteristics of this steel for our calculations are the tensile yield strength (355 MPa) and the tensile ultimate strength (600 MPa).

On the whole, during the testing of computer-simulated calculation models, a lot of various stressed states (under load application to the steel segments) were studied and, accordingly, a large number of screenshots were captured. However, in this article, we have included only a small selection of the screenshots, which we believe are the most illustrative.

By virtue of the symmetry of the artillery projectile relative to the longitudinal axis, a substructure method was used to simplify the calculations, therefore, as the

1st computer-simulated calculation model (model No. 1), as basic one, a substructure (segment) of the projectile that does not have the cut groove for the corrective weight was chosen – that is, for the case of the walls of the projectile body that had not undergone the operation of correcting the unbalance vector by metalworking. The initial and obtained data of the testing of model No. 1 are presented in *Fig. 7*. The value of calculated stress was $\sigma_z = 105.8$ MPa.

The 2nd computer-simulated calculation model (model No. 2) was a substructure (segment) of the projectile in the case of end part wall of the projectile body with the dovetail-shaped cut groove for the corrective weight, which was located in the bottom plane. The value of the calculated stress was $\sigma_z = 106.7$ MPa, and in the stress concentration zone of a local nature, the maximum value amounted to 320.6 MPa.

The 3rd computer-simulated calculation model (model No. 3) was a substructure (segment) of the projectile in the case of the end part wall of the projectile body after the performed operation of correcting the unbalance vector using metalworking means by way of removing excess metal particles by milling, where the groove has the shape of a semicircle and which is located in the bottom plane. The value of calculated stress was $\sigma_z = 105.8$ MPa.

The initial and obtained data of the testing of models No. 2 and No. 3 are presented in *Fig. 8* and *Fig. 9*, respectively.

The 4th computer-simulated calculation model (model No. 4) was a substructure (segment) of the projectile in the case of lateral wall of the projectile body without the cut groove for the corrective weight.

The initial and obtained data of the testing of model No. 4 are presented in *Fig. 10*.

The 5th computer-simulated calculation model (model No. 5) was a substructure (segment) of the projectile in the case of lateral wall of the projectile body with the cut groove for the corrective weight.

The initial and obtained data of the testing of model No. 5 are presented in *Fig. 11*.

Processing the obtained data and performing the calculations

According to the steel characteristics, for the wall of the projectile body, the tensile yield strength of material (σ_{TYS}) is 355 MPa, and the tensile ultimate strength of material (σ_{TUS}) is 600 MPa. The standard safety factor was taken to be equal to 2 ($n_T = 2$), and in this case the permissible yield strength of the material was

$$[\sigma] = \frac{\sigma_{TYS}}{n_T} = \frac{355}{2} = 177.5 \text{ (MPa)}. \quad (1)$$

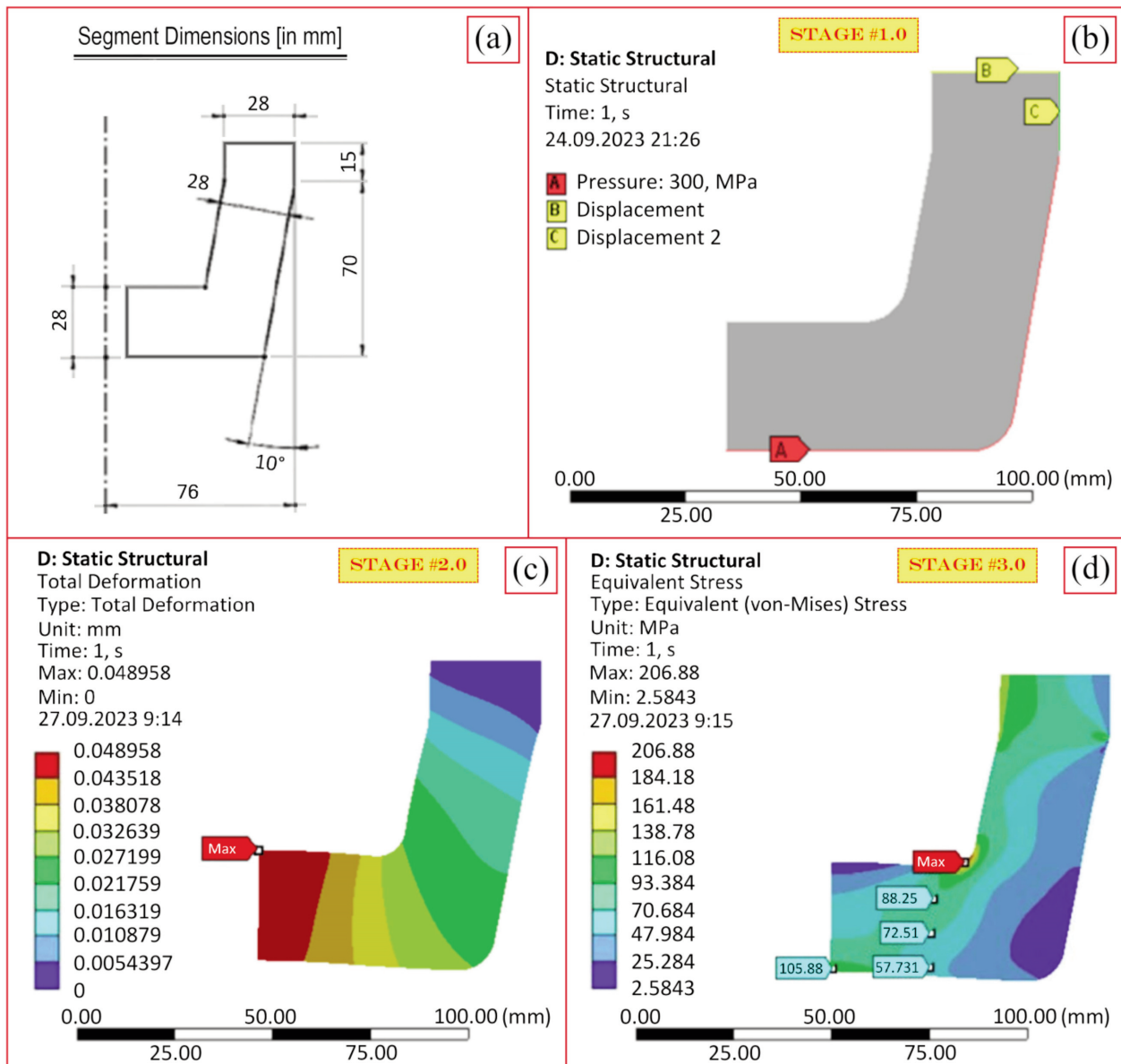

Figure. 7. Testing of model No. 1: (a) dimensioned sketch; (b)–(d) test stages

For the model with the groove in the form of an isosceles trapezoid of the dovetail type, the strength condition is satisfied:

$$\sigma_z = 106.7 \leq [\sigma] = 177.5 \text{ (MPa)}. \quad (2)$$

For the model with the groove made by milling in the form of a semicircle, the strength condition is satisfied as well:

$$\sigma_z = 118.8 \leq [\sigma] = 177.5 \text{ (MPa)}. \quad (3)$$

While performing the testing of the models taking into account the cut grooves, the stress fields of the wall of the projectile body were within the permissible (standardized) limits for the steel adopted in the calculations. Jumps in the calculated stresses (for the

dovetail-shaped groove $\sigma_z = 320.6$ MPa and for the semicircle groove $\sigma_z = 210.48$ MPa) were present only in the concentration zones, and although they exceeded the permissible (standardized) values of the tensile yield strength of material ($\sigma_{TYS} = 355$ MPa), they were local in nature and did not exceed the tensile ultimate strength of material ($\sigma_{TUS} = 600$ MPa). Based on this, the following primary inferences were made:

- The presence of the cut groove in the end part of the projectile body (in the bottom) does not affect the overall strength of the projectile body and does not lead to its damage under the influence of a pressure of 300 MPa caused by powder gases in the gun barrel during firing.

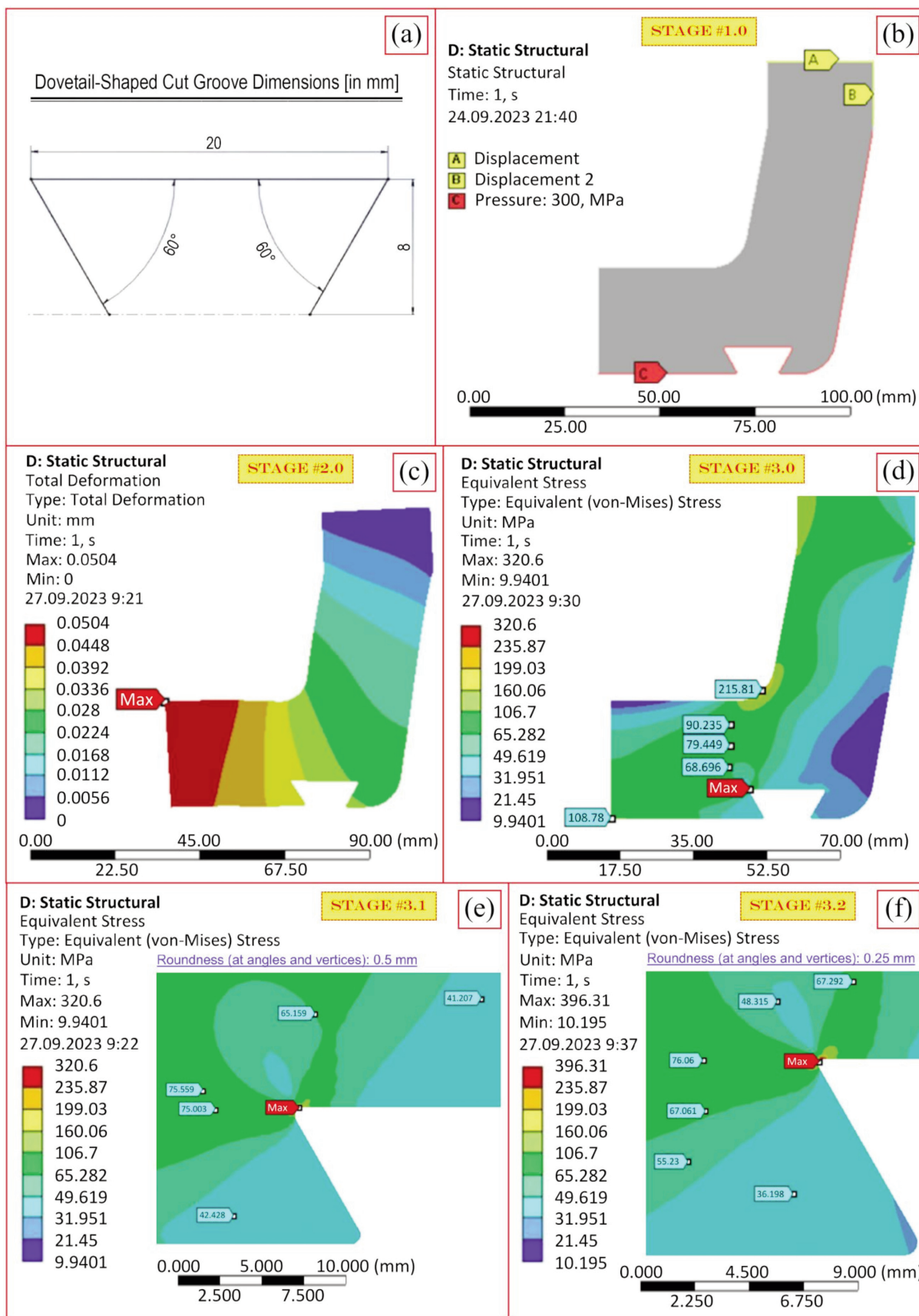

Figure 8. Testing of model No. 2: (a) dimensioned sketch; (b)–(f) test stages

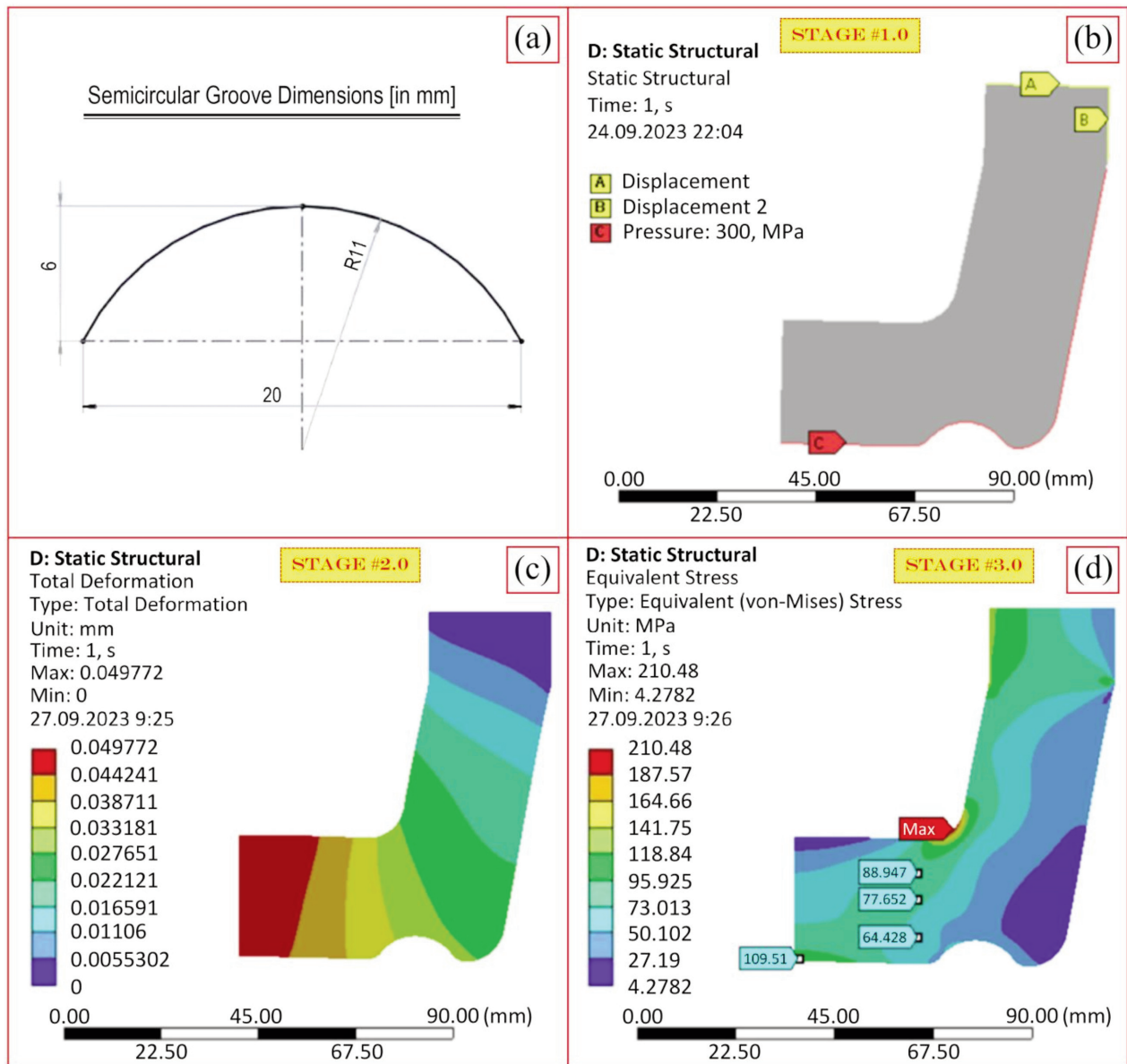

Figure. 9. Testing of model No. 3: (a) dimensioned sketch; (b)–(d) test stages

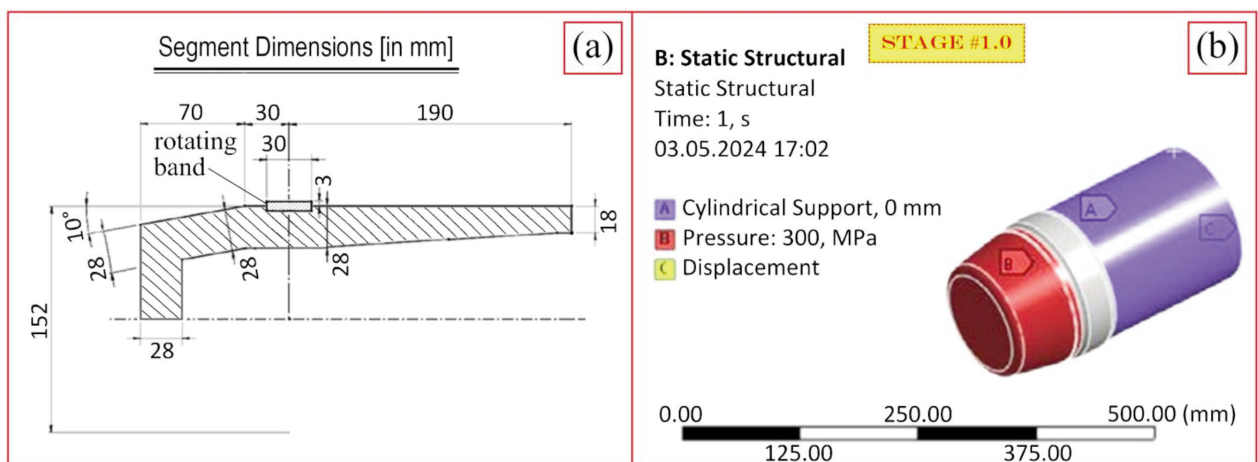

Figure. 10. Testing of model No. 4: (a) dimensioned sketch; (b)–(e) test stages

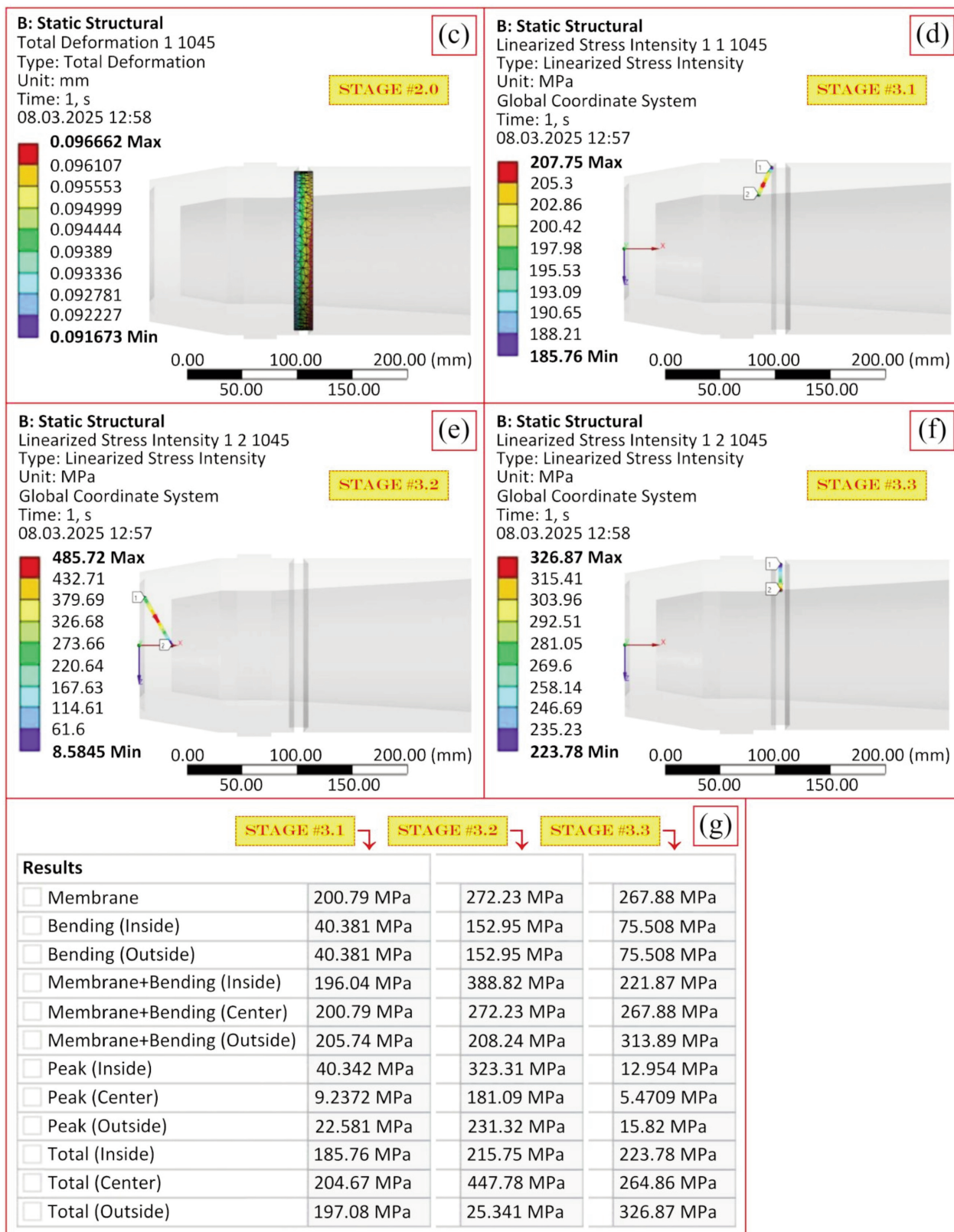

Figure. 11. Testing of model No. 5: (a) dimensioned sketch; (b)–(g) test stages

• Initiation of local deformations (expansion, elongation) of the geometric size of the groove can take place only in stress concentration zones, which will not affect the value of the residual unbalance, since the corrective weight, at the expense of friction forces in the upper part of the groove and the trapezoidal shape of the dovetail itself, will remain at its calculated location of correcting the unbalance vector without moving along the circumference of the groove.

The rotating band, by its purpose, plays the role of not only a guide along the barrel rifling, but also serves as a seal between the wall of the projectile body and the inner surface of the gun barrel to improve obturation. Therefore, the wall thickness of a 152 mm calibre projectile (see Fig. 6) at the end rare part (28 mm) and on the lateral surface after the rotating band of the projectile structurally differs (25–18 mm), since the maximum pressure of the powder gases acting on the body before the rotating band is 300 MPa, and after it is 100 MPa (according to the said textbook [14]).

Calculations of linearized stresses for models No. 5 and No. 2 were carried out taking into account different widths (8–24 mm) and depths (4.5–8 mm) of the cut groove for the corrective weight – that is, with different cross-sectional areas of this groove. The obtained data of the linearized stresses are presented in Tables 2 and 3.

Taking into account the standard safety factor of the projectile body walls equal to 2 (i.e., $n_T = 2$), a comparison was made between two types of steel for the projectile body: AISI 1045 normalized carbon steel with $\sigma_{TYS} = 355$ MPa and $\sigma_{TUS} = 600$ MPa and St45Cr structural alloy steel (chrome-containing) with $\sigma_{TYS} = 835$ MPa and $\sigma_{TUS} = 1030$ MPa [15].

For AISI 1045 steel, the maximum value of permissible stress in the walls of the projectile body

should not exceed $[\sigma] = 177.5$ MPa. According to the data obtained, the minimum combined stresses (membrane + bending) for case No. 1 (see Table 2) are $\sigma_z = 313.89$ MPa. It follows from this that

$$\sigma_z = 313.89 \gg [\sigma] = 177.5 \text{ (MPa)}. \quad (4)$$

For St45Cr steel, the maximum value of permissible stress in the walls of the projectile body should not exceed $[\sigma] = 417.5$ MPa. According to the obtained data on combined stresses (membrane + bending) for cases No. 1–9 (Table 2) and case No. 1 (Table 3), the condition of compliance with the standard safety factor of the projectile body walls ($n_T = 2$) $\sigma_z \leq [\sigma]$ is met:

$$\sigma_z [\text{No. 9 in Table 2}] = 416.47 \leq [\sigma] = 417.5 \text{ (MPa)}. \quad (5)$$

In confirmation of the obtained data from the testing of computer-simulated models, a checking calculation was performed using the Lamé's formula:

$$\sigma_z = \frac{p_i r_i^2 - p_o p_o^2}{r_o^2 - r_i^2} + \frac{(p_i - p_o) r_i^2 r_o^2}{(r_o^2 - r_i^2) r^2}, \quad (6)$$

where: p_i = internal pressure; p_o = external pressure; r_i = internal radius; r_o = external radius; r = current radius in the cylinder body.

For case No. 9 (Table 2) we have the corresponding values:

$$p_i = 0 \text{ MPa}; p_o = 100 \text{ MPa}; r_i = 51 \text{ mm}; \\ r_o = 68 \text{ mm}; r = [r_i; r_o].$$

The outer surface of the groove $r = r_o$:

$$\sigma_z^{\text{outer}} = \frac{0 \times 51^2 - 100 \times 68^2}{68^2 - 51^2} + \frac{(0 - 100) \times 51^2 \times 68^2}{(68^2 - 51^2) \times 68^2} = \\ = -357.14 \text{ (MPa)}. \quad (7)$$

Table 2

Obtained data of the linearized stresses for model No. 5

No.	Thickness of the projectile body wall, mm	Geometric dimensions of the groove for the corrective weight			Membrane stresses, MPa	Bending stresses, MPa	Membrane + bending stresses, MPa
		Width, mm	Depth, mm	Cross-sectional area, mm ²			
1	25.0	8.0	4.5	36.0	267.88	75.508	313.89
2	25.0	8.0	6.0	48.0	277.01	74.185	318.57
3	25.0	8.0	8.0	64.0	294.49	71.06	333.25
4	25.0	16.0	4.5	72.0	285.99	75.662	343.78
5	25.0	16.0	6.0	86.0	298.89	76.014	354.24
6	25.0	16.0	8.0	128.0	321.042	70.745	380.39
7	25.0	24.0	4.5	108.0	303.33	76.586	368.53
8	25.0	24.0	6.0	144.0	318.8	76.439	385.54
9	25.0	24.0	8.0	192.0	344.17	74.186	416.47

Table 3

Obtained data of the linearized stresses for model No. 2

No.	Thickness of the projectile body wall, mm	Geometric dimensions of the groove for the corrective weight			Membrane stresses, MPa	Bending stresses, MPa	Membrane + Bending stresses, MPa
		Width, mm	Depth, mm	Cross-sectional area, mm ²			
1	28.0	8.0	4.5	36.0	272.23	152.95	388.82
2	28.0	8.0	6.0	48.0	285.11	194.52	453.3
3	28.0	8.0	8.0	64.0	308.38	246.29	532.25
4	28.0	16.0	4.5	72.0	315.85	272.54	566.65
5	28.0	16.0	6.0	86.0	295.16	211.12	493.29
6	28.0	16.0	8.0	128.0	313.25	246.29	548.96
7	28.0	24.0	4.5	108.0	334.76	317.33	634.56
8	28.0	24.0	6.0	144.0	352.43	337.60	664.86
9	28.0	24.0	8.0	192.0	331.86	287.76	603.92

The inner surface of the groove $r = r_o$:

$$\sigma_z^{\text{inner}} = \frac{0 \times 51^2 - 100 \times 68^2}{68^2 - 51^2} + \frac{(0 - 100) \times 51^2 \times 68^2}{(68^2 - 51^2) \times 51^2} = -457.14 \text{ (MPa)}. \quad (8)$$

Then, the relative errors between the computer simulation data and the calculations using the Lamé's formula were determined for the stresses on the outer and inner surfaces, respectively:

$$\Delta_o = \frac{357 - 273}{357} \times 100 = 23.5 \text{ (%)}, \quad (9)$$

$$\Delta_i = \frac{457.14 - 413.75}{457.14} \times 100 = 9.49 \text{ (%)}, \quad (10)$$

which is quite acceptable and indicates the adequacy of the models used, the reliability of the results obtained and the correctness of the assumptions made in the calculations.

Thus, if the projectile body is manufactured using steel with the same σ_{TYS} and σ_{TUS} values as AISI 1045 steel, the condition of compliance with the standard safety factor of the projectile body ($n_T = 2$) is not met and to cut a groove for the corrective weight in the end or side part of the body of such a projectile is senselessly. And vice versa, in the case of using steel with the same σ_{TYS} and σ_{TUS} values as St45Cr steel (or better), the permissible geometric dimensions of the groove by its cross-section for the corrective weight obtained in our study, for which the condition of the calculated margin of the ultimate strength is met in accordance with the minimum wall thickness of the projectile body, can be used in practice.

It is quite obvious that this study presents only a small part of the complete set of all screenshots taken during the testing of models, since this work is a demonstration of the results of scientific research (taking into account the known issued patents associated with it), and not an instruction manual for a workshop metalworker.

Conclusions

1. Based on the obtained data of the linearized stresses for cases No. 1–9 (Table 2) and case No. 1 (Table 3), it is possible to recommend that manufacturers improve the quality of producing 152 mm calibre artillery projectiles by improving their production technique at the expense of the introduction of the operation of correcting the residual unbalance, taking into account their subsequent marking and sorting into 5 classes (according to Ukrainian patents obtained by Mr. Boriak). The advisability of the introduction of such an operation is as follows:

- Reducing the total quantity of projectiles required to hit one target and, accordingly, reducing the costs of logistical support for military units.
- Gaining tactical superiority in combat operations at the expense of the accuracy of hitting pre-set targets.
- Reducing the financial expenditures by the state for the purchase of ammunition for the needs of the troops.

2. The results of the conducted study and the approach applied to the problem of increasing the accuracy of hitting a pre-set target are quite suitable (taking into account the checking calculations) also in relation to 155 mm artillery projectiles which are produced by many NATO countries.

References

1. Krzyzanowski S. How to Assess the Accuracy of Artillery Fire [Електронний ресурс] / S. Krzyzanowski // Scientific Journal of the Military University of Land Forces. – 2018. – Vol. 187, No 1. – P. 25–39. – Режим доступу : <https://doi.org/10.5604/01.3001.0011.7355>.
2. Indirect Fire: A Technical Analysis of the Employment, Accuracy, and Effects of Indirect-Fire Artillery Weapons [Електронний ресурс] / O. S. Dullum, K. Fulmer, N. R. Jenzen-Jones et al. // ARES. – Published in January 2017. – Режим доступу : https://armamentresearch.com/wp-content/uploads/2017/01/ARES-Special-Report-Indirect-Fire_web.pdf.
3. Faria A. S. R. Kinematics of a Projectile Motion and the Hidden Curves of a Parabolic Trajectory [Електронний ресурс] / A. S. R. Faria, V. Soares, A. C. Tort // Latin-American Journal of Physics Education. – 2023. – Vol. 17, No 4. – P. 4306-1–4306-5. – Режим доступу : http://www.lajpe.org/dec23/17_4_06.pdf.
4. Стрільба артилерії : підручник / В. М. Петренко, В. Є. Житник, В. І. Макеєв та ін. – Суми : Сумський державний університет, 2012. – 757 с.
5. Improvement in Quality of Manufacturing the Large-Caliber Artillery Projectiles (122, 152, 155) for Guns with a Rifled Tube / K. F. Boriak, S. V. Lienkov, O. A. Nazarenko, O. V. Sieliukov // Зб. наук. праць Військового інституту КНУ ім. Т. Шевченка. – 2023. – № 78. – С. 7–17.
6. Boriak K. F. The Improvements of Ballistic Characteristics of Artillery Projectiles of 152 and 155 mm Calibers [Електронний ресурс] / K. F. Boriak // Bulletin of the Military University of Technology. – 2023. – Vol. 72, No 2. – P. 83–96. – Режим доступу : <https://doi.org/10.5604/01.3001.0054.3657>.
7. Спосіб балансування роторної деталі [Електронний ресурс] : пат. на корис. модель 23039 Україна : МПК G01G1/00 / заявник, винахідник та власник К. Ф. Бор'як. – № u200610892 ; заявл. 16.10.2006 ; опубл. 10.05.2007, бюл. № 6/2007 // Спеціальна інформаційна система УКРНОІВІ. – Режим доступу : <https://sis.nipo.gov.ua/uk/search/detail/305736>.
8. Спосіб калібрування артилерійських снарядів [Електронний ресурс] : пат. на корис. модель 154759 Україна : МПК F42B10/02 / заявник, винахідник та власник К. Ф. Бор'як. – № u202302454 ; заявл. 23.05.2023 ; опубл. 13.12.2023, бюл. № 50/2023 // Спеціальна інформаційна система УКРНОІВІ. – Режим доступу : <https://sis.nipo.gov.ua/uk/search/detail/1775433>.
9. Спосіб сортування артилерійських снарядів [Електронний ресурс] : пат. на корис. модель 155464 Україна : МПК F42B10/02 / заявник, винахідник та власник К. Ф. Бор'як. – № u202304729 ; заявл. 06.10.2023 ; опубл. 28.02.2024, бюл. № 9/2024 // Спеціальна інформаційна система УКРНОІВІ. – Режим доступу : <https://sis.nipo.gov.ua/uk/search/detail/1786149>.
10. Method for Reducing an Imbalance of a Projectile Shell [Електронний ресурс] : Patent Application Publication US-20230099611-A1 U.S. : int. cl. G01M1/12, F42B30/08, F42B33/00 / applicant Rheinmetall Wafle Munition GmbH ; inventors Th. Kadur, M. Kuffner, H. Radies. – Appl. No 18/073848 ; filed Dec. 2, 2022 ; published Mar. 30, 2023 // USPTO. Patent Public Search. – Режим доступу : <https://ppubs.uspto.gov/basic>.
11. Method and Apparatus for Reducing Projectile Spread [Електронний ресурс] : Patent US-4765566-A U.S. : int. cl. B21K021/06, F42B013/00 / inventors J.-Ol. Fixell, Th. Gustafsson, G. Hцgberg et al. – Appl. No 07/021827 ; filed Mar. 4, 1987 ; issued Aug. 23, 1988 // USPTO. Patent Public Search. – Режим доступу : <https://ppubs.uspto.gov/basic>.
12. Справочник по балансировке / под ред. М. Е. Левита. – М. : Машиностроение, 1992. – 464 с.
13. Datasheets for Guns, Howitzers, and Mortars Interoperable Ammunition [Електронний ресурс] : Technical Manual : TM 43-0001-28-3 / Headquarters, Department of the Army. – [Washington, DC : Headquarters, Department of the Army], 1986. – 148 p. // Hathitrust. – Режим доступу : <https://hdl.handle.net/2027/uva.x004948595>.
14. Дерев'янчук А. Й. Основи будови артилерійських гармат та боеприпасів : підручник / А. Й. Дерев'янчук. – Суми : Сумський державний університет, 2011. – 716 с.
15. Прокат из легированной конструкционной стали. Технические условия : ГОСТ 4543–71. – Изд. декабрь 2000 с Изм. 1, 2, 3, 4, 5 (ИУС 5-77, 11–82, 5–87, 10–87, 3–90). – Введ. 01.01.73. – М. : Изд-во стандартов, 2001. – 40 с.

Надійшла до редакції: 07.02.2026

Прийнята для опублікування: 13.03.2026